



Status on Waltham upstream

From AGL to Wayland community

24-Sep-2019 ADIT

Outline

- Status on Waltham implementation as standalone backend
- Waltham backend requirements
- Next steps + discussion

Waltham Plugin (Weston < 7.0)

- Waltham-Transmitter plugin : Handle connection and transmit surface
- Waltham-Receiver: Receive buffer from transmitter.

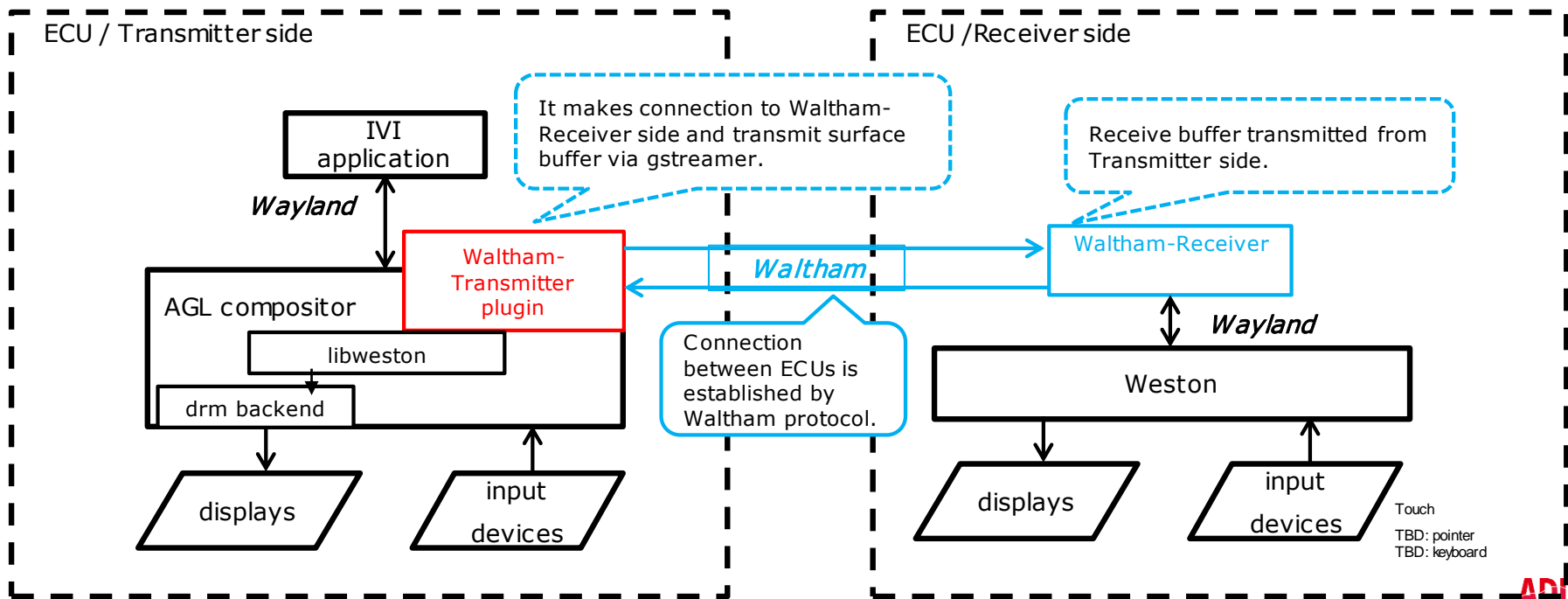

Waltham backend (Weston >= 7.0) functionalities remain same.

- Waltham **backend** : Handle connection and transmit surface
- Waltham-Receiver: remaining same.

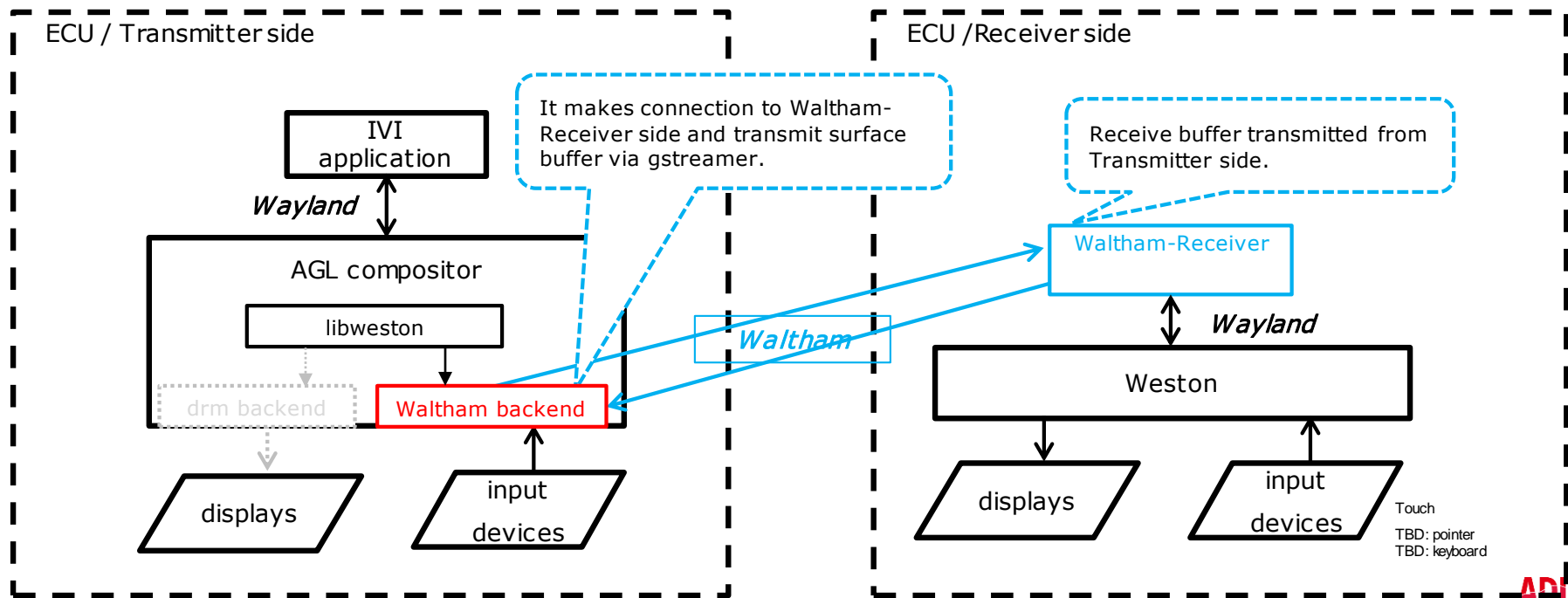

High level Waltham backend requirements

- ◆ input handling:
 - keypoint input
 - pointer input
 - useful for AXIS events
 - touch input
 - local coordinates are shared: receiver is always sent local coordinate along with the surface...
 - (prio2) also global display coordinate should be able to share.
 - notification about the input devices availability on the remote site.
- ◆ surfaces sharing:
 - it shall be possible to share a single surface.
 - it shall be possible to share multiple surfaces separately.
 - (prio2) it shall be possible to share combined content from the complete display to remote site
- ◆ lifecycle management
 - it shall be possible to recover if transmitter or receiver disappears
 - needs more clarification what should be possible: waiting for connection, recovering connection, handle rebooting of one of the components(ether receiver or transmitter)

Next steps (Weston >= 7.0) as backend

■ Enable Weston to have multiple backends

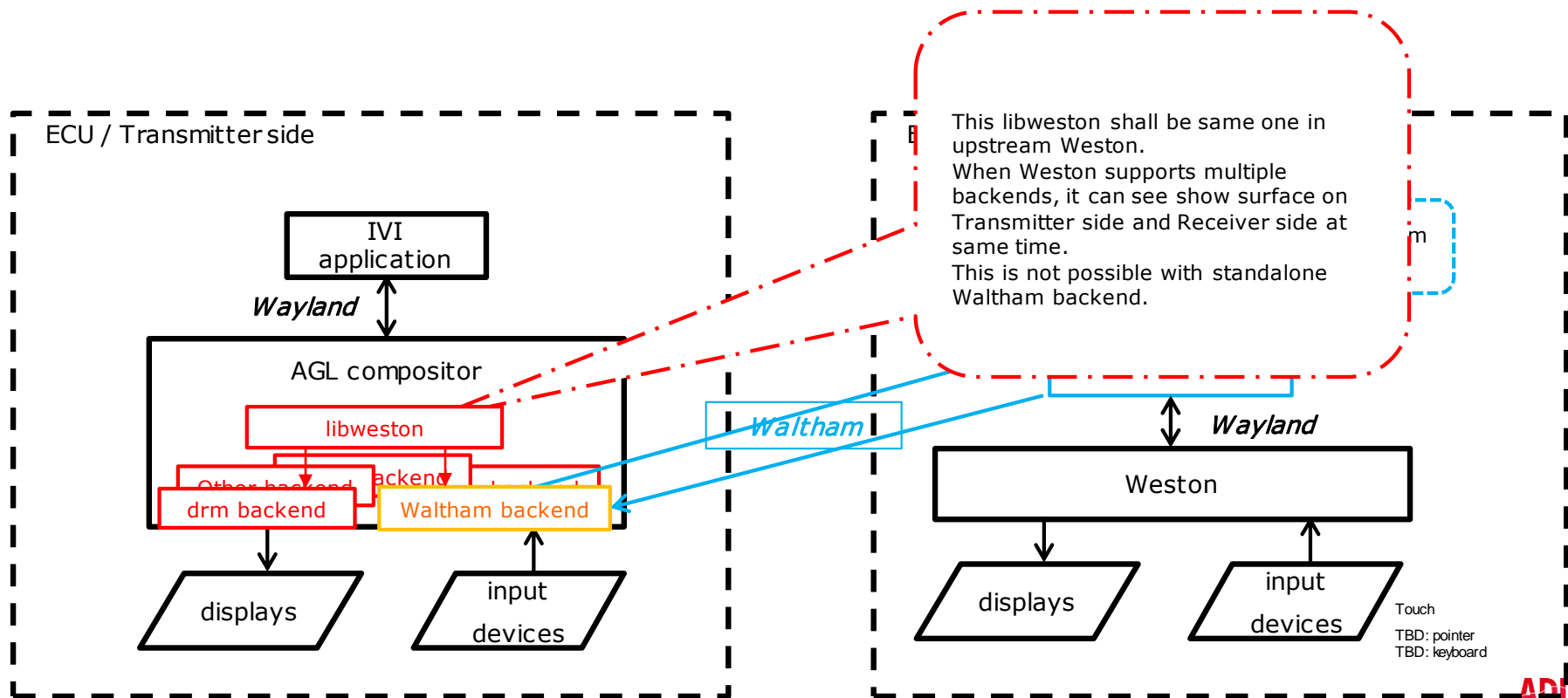

■ AGL

- ◆ Waltham transmitter upstream discussion from UI&GRA, March 2019
 - Waltham_transmitter_upstream_20190301_02.pptx
- ◆ Face to Face July in Tokyo 2019
 - <https://wiki.automotivelinux.org/agl-distro/jul2019-f2f-weston-multiple-backends.pptx>

■ Genivi

- ◆ GENIVI Technical Summit
 - <https://at.projects.genivi.org/wiki/display/WIK4/GENIVI+Technical+Summit+Session+Content+2018>
 - ◆ ADIT/Bosch Implementing Waltham in practice
 - ◆ Waltham in Practice - working session (Harsha Manjula Mallikarjun)
- ◆ GENIVI 18th All Member Meeting
 - <https://at.projects.genivi.org/wiki/display/WIK4/18th+GENIVI+AMM+Presentations>
 - ◆ Domain Interaction - Wayland-IVI-extension / Waltham Usage in Shared Graphics Environment